

RSU213T5120 • RSU213T5120WC

Ballast Type: Electronic
 Input Voltage: 120VAC ±10%
 Input Frequency: 50/60 Hz.

Starting Method: Preheat Rapid Start
 Lamp Connection: Parallel
 Unit Color: Galvanized

Unit Weight: 0.60 lb
 Carton Quantity: 50
 Skid Quantity: 1800

ELECTRICAL SPECIFICATION:

Line Voltage (V)	Lamp Type	Lamp Watts	No. of Lamps	Line Current (A)	Input Power (W)	Power Factor	Max Current THD (%)	Current Crest Factor	Ballast Factor	Wiring Diagram	B.E.F.
120	F8T5 & F13T5	8 & 13	2	0.33	20	≥0.51	≤140	≤1.5	0.84	065	4.20
120	F13T5	13	2	0.39	25	≥0.51	≤140	≤1.4	0.81	065	3.24
120	F8T5	8	2	0.26	16	≥0.51	≤140	≤1.5	0.95	065	5.93

PERFORMANCE:

- Electronic ballast
- Preheat rapid start
- Parallel operation
- Normal power factor
- Encased & potted
- Sound rated A
- End-of-Lamp Life protection
- Internal surge protection
- Meets FCC Part 18 (Class B) EMI and RFI consumer limits
- Meets ANSI standard C82.11 (where applicable)
- Meets ANSI standard C62.41

APPLICATION:

- Maximum case temperature: 167°F/75°C
- Maximum ambient temperature: 104°F/40°C
- Minimum starting temperature: -4°F/-20°C
- Not recommended for extreme temperature variations
- Lamp starts: >15,000 starts
- Remote mounting: 18 ft.

SAFETY:

- UL/935 (Class P, Type HL, Type CC, Type 1 outdoor) listed
- CSA (cUL) certified
- CSA/C22.2 certified
- Inherent Thermal Protection
- RoHS Compliant
- No PCB's

STYLE:

3B

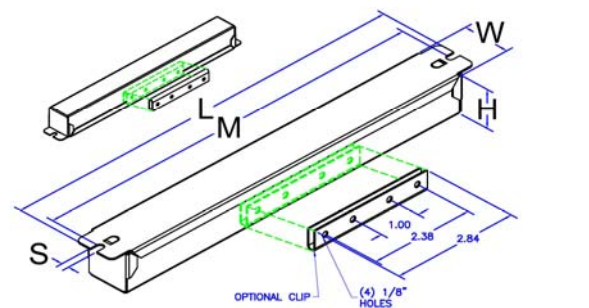

H	W	L	M	S
31/32	29/32	9 1/16	8 3/4	5/32
0.97	0.91	9.06	8.75	0.16
2.46 cm	2.31cm	23.01cm	22.23 cm	0.41cm

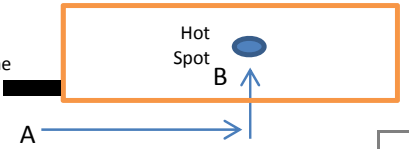

A	B
3.9"	0.5"

WIRING DIAGRAM:

065

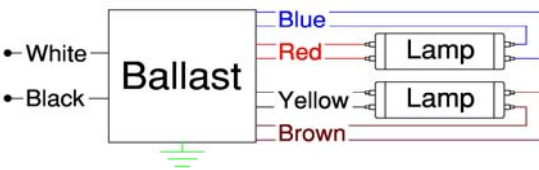

Standard lead lengths:

- Blk: 24"
- Wht: 24"
- Red: (2) 24"
- Blu: (2) 24"
- Yel: (2) 24"
- Brn: (2) 24"

Available in:

- With Clip - RSU213T5120WC

WARRANTY:

Robertson Worldwide warrants to the purchaser that this ballast will be free from defects in material or workmanship for a period of 2 years from date of manufacture when properly installed and under normal conditions of use. For more information on Robertson Worldwide's ballasts, call 1-800-323-5633 or visit www.robertsonww.com. For our energy star compliant ballasts, visit www.nema.org/lampballastmatrix/ Specifications subject to change without notice.

Revised 12/21/11

ROBERTSON WORLDWIDE

13611 Thornton Rd, Blue Island, IL 60406, TEL: 1-800-323-5633, FAX: 1-877-388-2420, www.robertsonww.com